



3 Way Ball Valves PN 20 (Class 150) AIT & IIT Construction (Carbon & Stainless Steel)

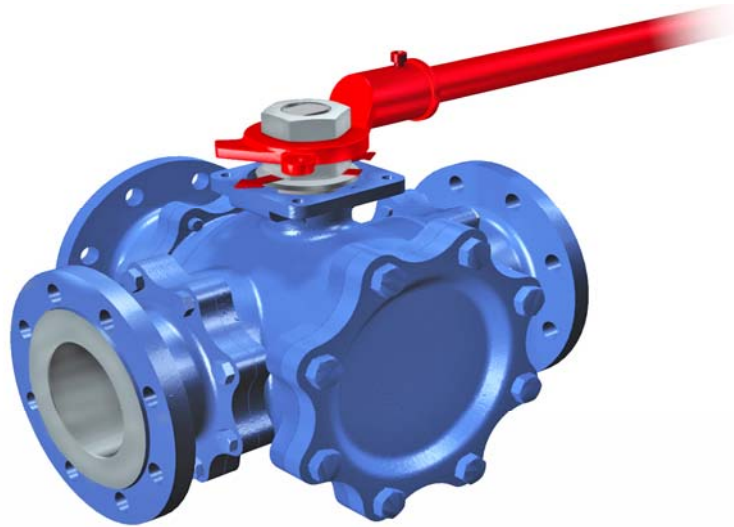

Fig. 915 L or T port

Manufacturing program:



Quality & Environmental Management:



Comercial de Válvulas y Accesorios, S.A.
Polígono Industrial Polizur, Calle Bosc Tancat, 6 Nave 2 y 3
08290 Cerdanyola del valles (Barcelona) – Spain Tel. 34 93 586 36 00 Fax 34 93 586 36 04
e-mail: info@cva.es
URL: www.jlx-valve.com

Remarks: The dimensions of this catalogue are for reference only and it can change without previous notice

SERIES
MFF

3 Way Ball Valves PN 20 (Class 150)

Parts and materials

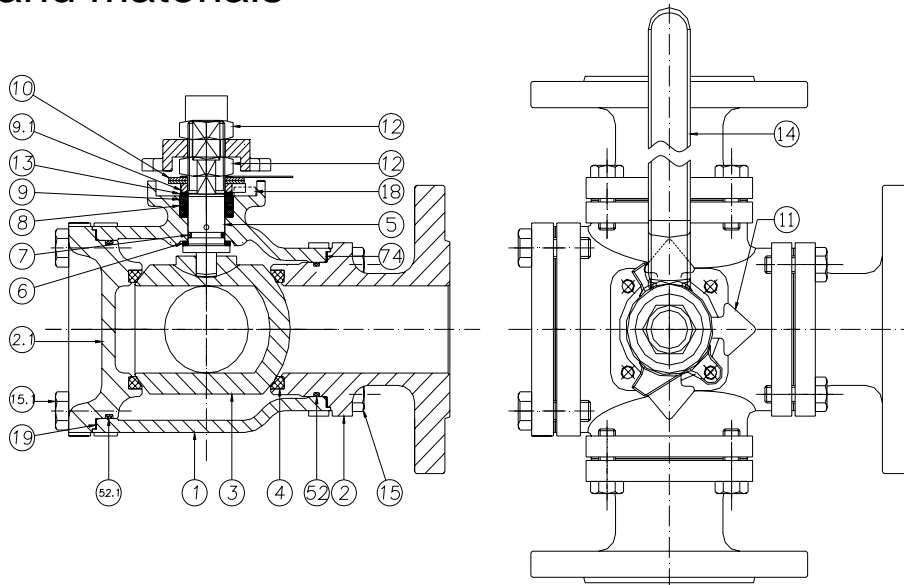

Item	Description	Material	
		AIT	IIT
1	Body	A216 Gr. WCB (C=0,25%)	A351 Gr. CF8M
2	Body connector	A216 Gr. WCB (C=0,25%)	A351 Gr. CF8M
2.1	Side Cover	A216 Gr. WCB (C=0,25%)	A351 Gr. CF8M
3	Ball	A 351 Gr. CF8M	
4	Seat ring	PTFE	
5	Stem	A 479 Type 316	
6	Stem thrust seal	25%GF PTFE	
7	O'ring	FKM	
8	Stem packing	Graphite	
9	Gland	AISI 303	AISI 316
9.1	Stop plate	F114	AISI 304
10	Disk spring	E.N.P Carbon steel	
11	Look. Wash. Pointer	Rilsan coated Carbon St.	
12	Gland nut	Zinc plated carbon steel	AISI 303
13	Antifriction washer	25%GF. PTFE	
14	Wrench	EN-GJL-250	
15	Bolt	DIN 933 A4 - 70	
15.1	Bolt	DIN 933 A4 - 70	
18	Stop bolt	A4-70	
19	Body cover seal	PTFE	
52	O'ring	FKM	
52.1	O'ring	FKM	
74	Body connector seal	PTFE	
89	Identification plate	Stainless St.	





3 Way Ball Valves PN 20 (Class 150)

Dimensions

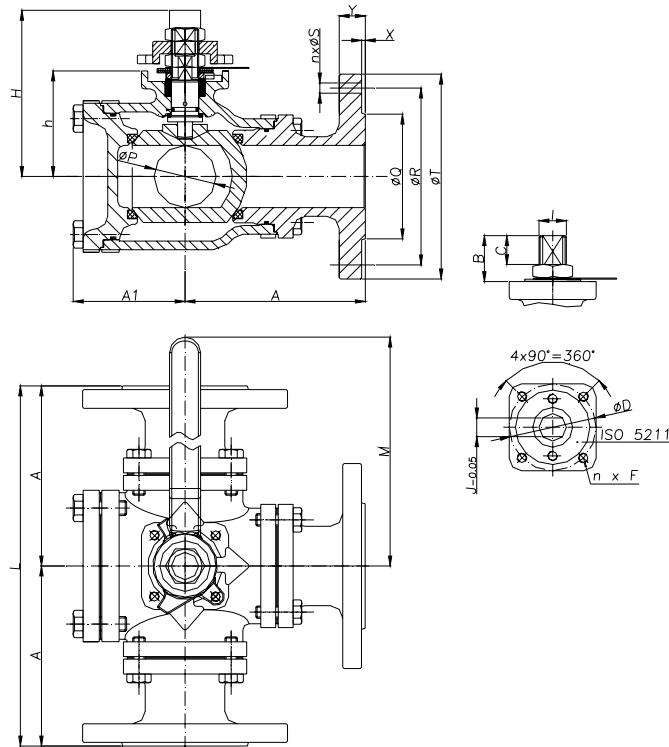

Valve with lever

DN	ØP	L	A	A1	H	h	M	ØT	ØR	ØQ	X	Y	n x ØS
1"	25	212	106	70	96	60	170	110	79,4	50,8	2	12,7	4x15,8
1½"	40	262	131	80	121	72	200	125	98,4	73	2	15,9	4x15,8
2"	50	290	145	90	134	85	350	150	120,7	92,1	2	17,5	4x19
2½"	65	325	162,5	107	180	101	350	180	139,7	104,8	2	20,7	4x19
3"	80	370	185	117	189	122	465	190	152,4	127	2	22,3	4x19
4"	100	430	215	148	230	146	475	230	190,5	157,2	2	22,3	8x19
6"	150	500	250	194	280	182	855	280	241,3	215,9	2	23,9	8x22
8"	200	600	300	270	325	255	855	345	298,5	269,9	2	27	8x22

(*) Dimensions in mm and weight in kg.

Free stem dimensions

DN	ISO 5211	B	C	ØD	n x F	I	J
1"	F05	22	12,2	50	4xM6	M12x1,5	8
1½"	F07	33	19,2	70	4xM8	M18x1,5	12
2"	F07	34	20,2	70	4xM8	M22x1,5	15
2½"	F10	34	19,2	102	4xM10	M22x1,5	15
3"	F10	45	27,7	102	4xM10	M28x1,5	19
4"	F12	59	32,2	125	4xM12	M36x1,5	24
6"	F14	69	41	140	4xM16	M48x3	32
8"	F14	69	34	140	4xM16	M48x3	32

(*) Dimensions in mm and weight in kg.



Comercial de Válvulas y Accesorios, S.A.
 Polígono Industrial Polizur, Calle Bosc Tancat, 6 Nave 2 y 3
 08290 Cerdanyola del valles (Barcelona) – Spain Tel. 34 93 586 36 00 Fax 34 93 586 36 04

e-mail: info@cva.es

URL: www.jlx-valve.com

Remarks: The dimensions of this catalogue are for reference only and it can change without previous notice

SERIES
MFF



3 Way Ball Valves PN 20 (Class 150)

General Characteristics, Torque & Kv , P&T Rating

GENERAL CHARACTERISTICS	Fig.915 Series MFF	M ultiport	F loating Ball	F ull Bore
DESIGN STANDARDS				
Valves design	ASME B16.34			
Shell thickness	ASME B16.34			
Flanges	ASME B16.5			
Face to face dimensions	Manufacturer Standards			
Shell finishing quality	MSS SP 55			
Marking	BS 5351	EN 19	CE - PED	
Actuator mounting flange	ISO 5211	EN 15081		
TESTS AND CERTIFICATES				
Quality Assurance	ISO 9001	CE - PED		
Pressure testing	BS 6755 Part 1	ISO 5208	EN 12266	
Other	ISO 14001	ATEX		

Torque Values in Nm

VALVE SIZE	AT DIFFERENTIAL PN 20 (Class 150)	
	L	T
25 (1")	32	32
40 (1 ½")	71	71
50 (2")	130	130
65 (2½")	195	195
80 (3")	260	260
100 (4")	494	494
150 (6")	689	689
200 (8")	850	850

Port combinations

3 WAY **L** PORT

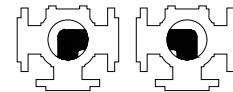

3 WAY **T** PORT

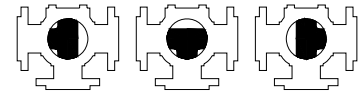

3 WAY INVERTED **T** PORT

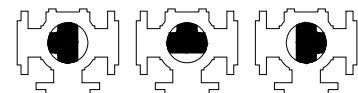

Kv Values in m³/h

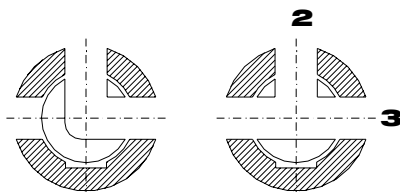

DN	PORT L	PORT T	
		PORT 2	PORT 3
25 (1")	20,4	28,9	51
40 (1 ½")	51,85	51,85	149,6
50 (2")	42,5	80,75	249,9
65 (2½")	136,85	136,85	478,55
80 (3")	206,55	291,55	732,7
100 (4")	323	323	1217,2
150 (6")	726,75	726,75	3087,2
200 (8")	920	920	4810

Pressure-Temperature

For A216 Gr. WCB only. For other materials consult ASME B16.34

P Bar

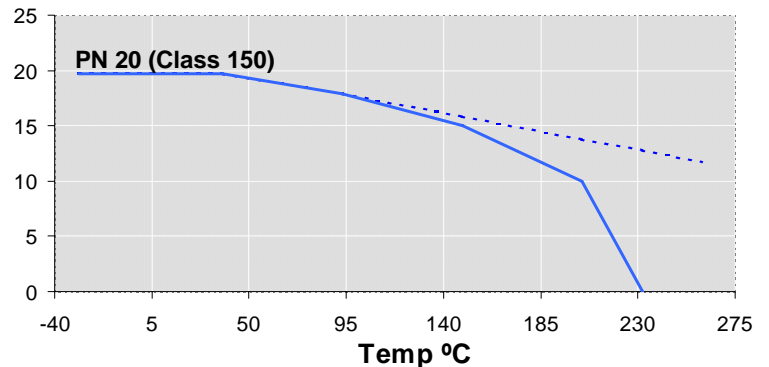

Comercial de Válvulas y Accesorios, S.A.
 Polígono Industrial Polizur, Calle Bosc Tancat, 6 Nave 2 y 3
 08290 Cerdanyola del valles (Barcelona) – Spain Tel. 34 93 586 36 00 Fax 34 93 586 36 04
 e-mail: info@cva.es
 URL: www.jlx-valve.com

SERIES
MFF

Remarks: The dimensions of this catalogue are for reference only and it can change without previous notice