

Forged Gate Valves Class 150/300
Fig. C150RF & C300RF
Size ½” – 2” (DN 15 – 50)



FIG. C150RF
FIG. C300RF
GATE VALVE

API, MSS SP & ASME B16.34

Connections according to:

ASME B16.5



Forged Gate Valves Class 150/300

Fig. C150RF & C300RF

Parts and Materials

Parts and materials

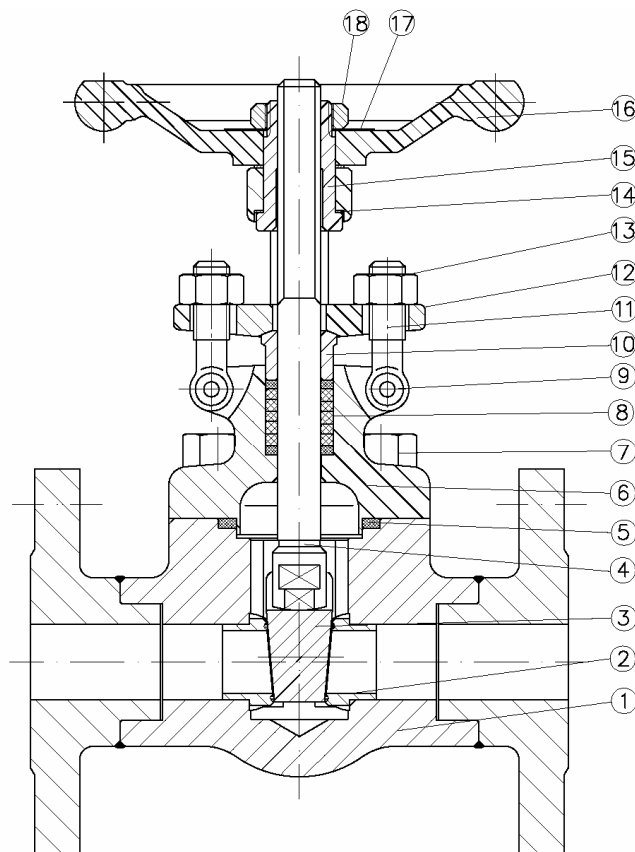

Item	Description	Material	
		Carbon Steel	Stainless Steel
1	Body	A 105	A 182 F316L
2	Seat	A 182 F6A + STL	A 182 F316L + STL
3	Gate	A 182 F6A + STL	A 182 F316L
4	Stem	AISI 410	A 182 F316L
5	Gasket	AISI 304 + Graphite	AISI 316 + Graphite
6	Bonnet	A 105	A 182 F316L
7	Bolt	A 193 B7	A 193 B8M
8	Packing	Flexible Graphite + Carbon Fibre	
9	Pin	AISI 420	AISI 304
10	Packing Gland	AISI 420	AISI 316L
11	Eye Bolt	A 193 B8	A 193 B8M
12	Gland Flange	A 105	A 182 F316L
13	Hex Nut	A 194 8	A 194 8M
14	Washer	AISI 410	
15	Yoke Nut	AISI 410	
16	Handw heel	A 197	
17	Nameplate	Aluminium	
18	Hex Nut	1035 Zinc Plated	

Forged Gate Valves Class 150/300

Fig. C150RF & C300RF

Dimensions

Dimensions

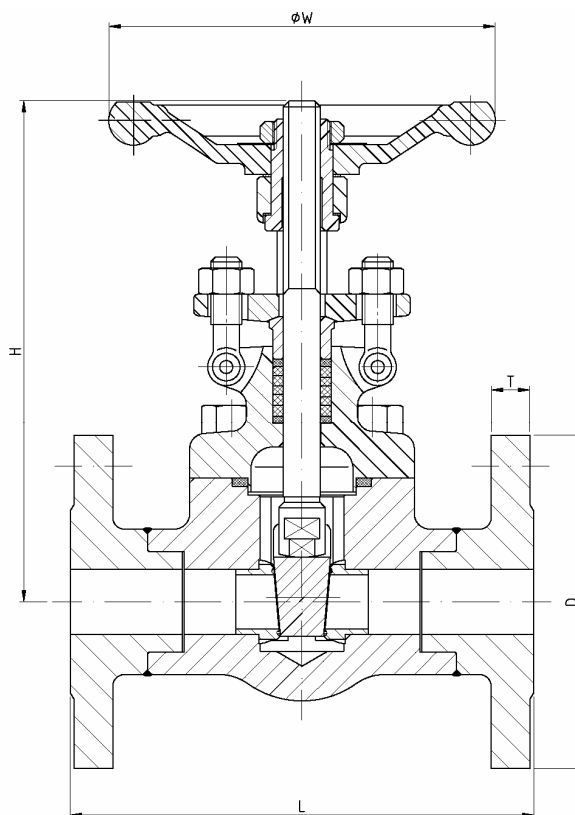

Series C150RF (Class 150)

SIZE	L	D	T	W	H	WEIGHT
½" (DN 15)	108	89	11,5	100	166	3,3
¾" (DN 20)	117	98	13	100	163	4
1" (DN 25)	127	108	14,5	125	193	6
1¼" (DN 32)	140	118	16	160	230	7
1½" (DN 40)	165	127	17,5	160	246	10
2" (DN 50)	178	152	19,5	180	263	16

(*) Dimensions in mm and weight in kg.

Series C300RF (Class 300)

SIZE	L	D	T	W	H	WEIGHT
½" (DN 15)	140	95	14,5	100	166	4,8
¾" (DN 20)	152	118	16	100	163	6,2
1" (DN 25)	165	124	17,5	125	193	9,3
1¼" (DN 32)	178	133	19,5	160	230	14
1½" (DN 40)	190	156	21	160	246	15,5
2" (DN 50)	216	165	22,5	180	263	23

(*) Dimensions in mm and weight in kg.

Forged Gate Valves Class 150/300

Fig. C150RF & C300RF

General Characteristics, Torque, KV, P&T Rating

GENERAL CHARACTERISTICS	Forged Gate Valve		
DESIGN STANDARDS			
Valves design	API 602	ASME B 16.34	
Connections	ANSI B 1.20.1	ANSI B 16.11	
Face to face dimensions	ASME B16,10		
TESTS AND CERTIFICATES	API 598		
Quality Assurance	ISO 9001		
Pressure testing	EN 12266-1		
Marking	EN 19		

(*) Welded flanges

Kv Values in m³/h

VALVE SIZE	Kv	VALVE SIZE	Kv
½" (DN 15)	15	1¼" (DN 32)	80
¾" (DN 20)	15	1½" (DN 40)	80
1" (DN 25)	29	2" (DN 50)	135

Pressure-Temperature

P Bar

