

**PRESSURE TRANSMITTER
FOR GENERAL APPLICATIONS**

Type. XA-904.L



1. DESCRIPTION

This series of pressure transmitters and made of stainless steel **AISI-904.L** has been developed to cover the majority of industrial applications. They are usual those ones that are dedicated to the continuous measurement of gases or liquids, mechanical engineering, hydraulics, pneumatic, etc.

The transmitter is made with the most novel techniques and it has inside of it a converter circuit of high quality it can be supplied with a non-stabilized direct voltage of 8 (15) ... 35 Vdc. And provide standard industrial output signals (see maximum load R).

This whole range of transmitters can be adapted to our program of cooling towers for high process temperatures applications and for the whole range of diaphragms for the chemical industry, food industry, pharmaceutical, etc.

2. USED TECHNIQUE

The sensor of the pressure transmitter is made of ceramic, and the technique used to make it is called "piezoresistive". This technology is related to the deformation of the diaphragm, in it there are recorded 4 electric resistences making a Wheastone bridge. Because of that any deformation that the diaphragm can suffer caused by the effect of any pressure will unbalance the electric circuit that will conform an exit sign proportional and linearity to the pressure that supports the ceramic sensor.

The ceramic sensors used are internally compensated in temperature through resistences PTC.

The use of the ceramic technology in the field of the pressure transmitters contributes an excellent fiability because it makes the pressure directly in the ceramic sensor. On not having existed no chamber of fluids in its interior (synthetic oil, glycerine, etc... that could produce variations for dilatation effects) contributed a high stability opposed to the effects of the temperature.

3. PRESSURE RANGES (Bar)

Ranges	0,25	0,50	0,75	1,00	1,60	2,50	4,00	6,00
Burst pressure	3,00	3,00	3,00	3,00	5,00	12,0	12,0	25,0

Ranges	10,0	16,0	25,0	40,0	60,0	100	160	250
Burst pressure	25,0	50,0	120	120	250	250	500	500

Other pressure ranges and units are available (m.c.a., PSI, Kg/cm², mmHg, KPa,...)

4. TECHNICAL DATA

Pressure	Relative, absolute and vacuum
Pressure ranges	0-0,250 Bar to 0-250 Bar (for relative pressures) Pressure of vacuum and absolute (order pressure ranges and units are available)
Sensor	Ceramic piezoresistor
Accuracy – Combined error (hysteresis – linearity – reproducibility)	Typical $\leq 0,4$ % of span
Resolution of sensor	0,01 to 0,014 % of span
Response time	< 1 mseg.
Dielectric strength	2 KV
Materials wetted parts	Stainless steel AISI-904L, ceramic and o-ring
Material of the o-ring	VITON (Other materials: NBR, EPDM, PTFE...)
Material case	Stainless steel
Process connection	1/2 BSP
Degree of protection	IP-65
Signal output	Linearity
Power supply	8÷35 Vdc.
Wiring protection	Protected against reverse polarity, overvoltage and short circuiting
Signal output	4÷20 mAdc., 2 wire (other output can be adapted)
Maximum load R - Ω	$R_a \leq [U_b (Vdc.) - 8 (Vdc)] / 0,02 Adc.$
Electrical connection	4 pin connector Din 43650 EN60529 - PG9
Temperature	Process -5 a +90 °C Ambient -5 a +80 °C
Dimensions	See drawings
Weight	< 0,25 Kg. (with parking box and instructions)
CE - Conformity	89/336/CE-EN61000-6-2-97/23

5. DIMENSIONS (mm.)

5.1 Process connection

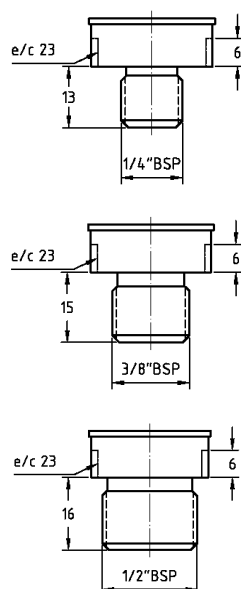

5.1 Dimensions case

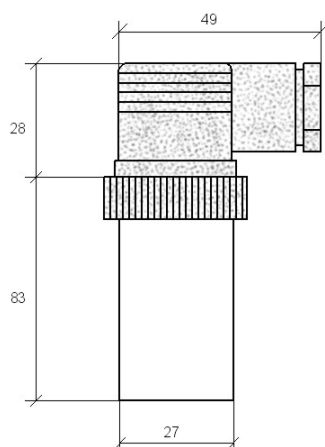

6. ELECTRICAL CONNECTION

6.1 With switching power supply

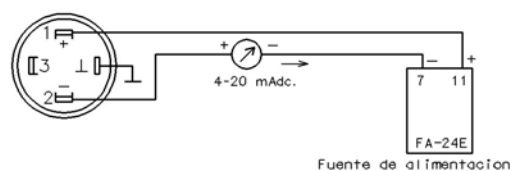

6.2 With amplifier relay for the transmitter

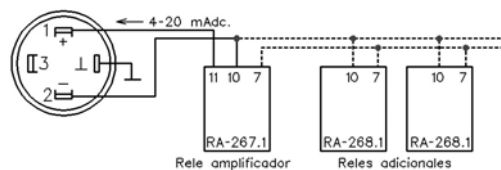

6.3 With panel meters – process display

