

Ball Valves PN 20/50 (Class 150/300) AIT & IIT Construction (Carbon Steel and Stainless Steel)



Fig. 715/730

API 6D and Fire Safe

Manufacturing program:

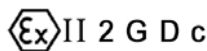

LICENSE NO. 6D-0197

Quality & Environmental Management:



Comercial de Válvulas y Accesorios, S.A.
Polígono Industrial Polizur, Calle Bosc Tancat, 6 Nave 2 y 3
08290 Cerdanyola del valles (Barcelona) – Spain Tel. 34 93 586 36 00 Fax 34 93 586 36 04
e-mail: info@cva.es
URL: www.jlx-valve.com

Remarks: The dimensions of this catalogue are for reference only and it can change without previous notice

Ball Valves PN 20/50 (Class 150/300)

DN 15 - 250 (1/2" – 10") PN 20 (Class 150)
 DN 25 - 200 (1" – 8") PN 50 (Class 300)

Parts and materials

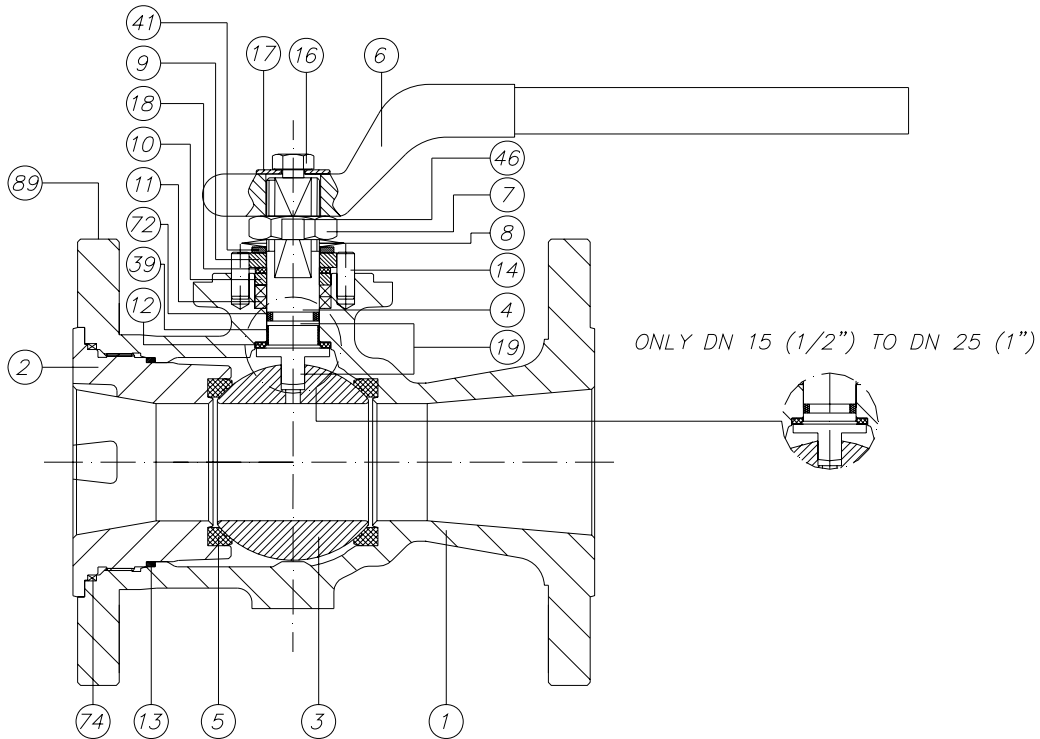

Item	Description	Material	
		AIT	IIT
1	Body	A 216 Gr. WCB (C ≤ 0,25%)	A 351 Gr. CF8M
2	Body connector	A 105	A 351 Gr. CF8M (DN 15 : 40 A 276/479 Tp.316)
3	Ball	A 351 Gr. CF8M (DN 15 : 25 A 479 Tp.316)	
4	Stem	A 479 Tp.316	
5	Seat ring	PTFE	
6	Wrench	Nodular Iron	
7	Gland nut	Zinc plated carbon steel	AISI 303
8	Disk spring	Carbon St.	E.N.P. Carbon St.
9	Stop plate	Carbon St.	AISI 304
10	Gland	AISI 303	AISI 316
11	Gland packing	Graphite	
12	Stem thrust seal	25% G.F. PTFE	
13	Body connector seal	PTFE	
14	Stop pin	Carbon St.	Stainless St.
16	Bolt	DIN 933 5.6 Zinc plated	DIN 933 A2
17	Washer	Zinc plated carbon steel	AISI 304
18	Thrust washer	25% G.F. PTFE	
19	Antistatic device	Stainless St.	
39	Stem bushing (DN 40 to 200)	25% G.F. PTFE	
41	Spacer (Dn 40 to 200)	Carbon St.	AISI 304
46	Locking Washer	AISI 304	
72	"O" Ring	FKM	
74	Insert seal	Graphite	
89	Identification plate	Stainless St.	



Comercial de Válvulas y Accesorios, S.A.
 Polígono Industrial Polizur, Calle Bosc Tancat, 6 Nave 2 y 3
 08290 Cerdanyola del valles (Barcelona) – Spain Tel. 34 93 586 36 00 Fax 34 93 586 36 04
 e-mail: info@cva.es

URL: www.jlx-valve.com

Remarks: The dimensions of this catalogue are for reference only and it can change without previous notice

Ball Valves PN 20/50 (Class 150/300)

DN 15 - 250 (1/2" - 10") PN 20 (Class 150)

DN 25 - 200 (1" - 8") PN 50 (Class 300)

Dimensions

WRENCH FOR DN 15 (1/2") TO DN 100 (4")

WRENCH FOR DN 150 (6") & DN 200 (8")

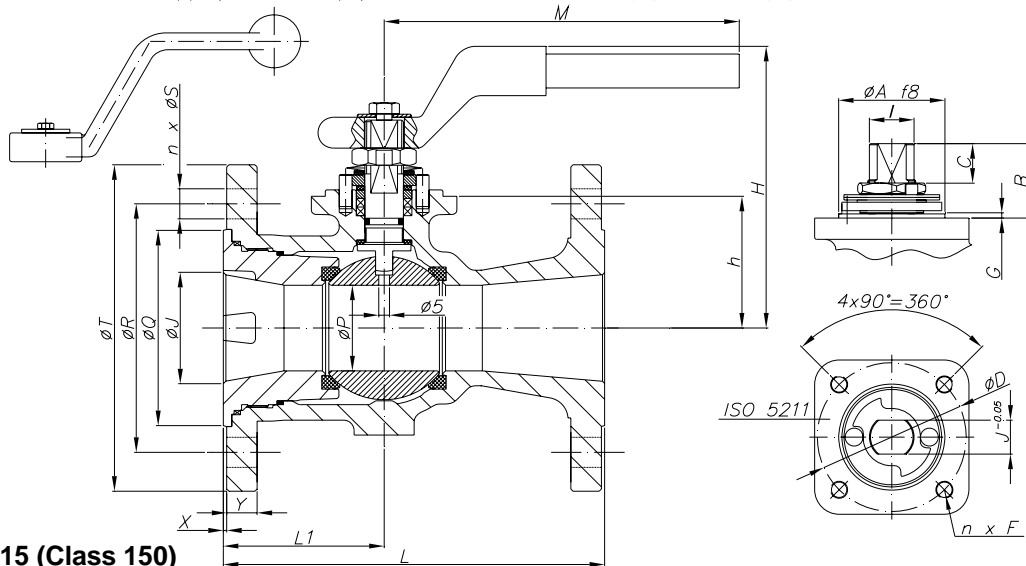

Series 715 (Class 150)

DN	ØJ	ØP	L	L1	ØQ	ØR	n x ØS	ØT	X	Y	h	H	M	WEIGHT
15 (1/2")	14,8	9,5	108	54	34,9	60,3	4x15,9	88,9	1,6	9,5	21,5	95,5	166	1,6
20 (3/4")	19,9	15	117	60	42,9	69,8	4x15,9	98,4	1,6	11,1	26	102	166	2,1
25 (1")	24,87	20	127	64,8	50,8	79,4	4x15,9	108	1,6	12,7	29	104,5	166	2,7
40 (1 1/2")	39,8	32	165	72	73	98,4	4x15,9	127	1,6	15,9	51	163	213,7	5,1
50 (2")	49,82	40	178	75,1	92	120,6	4x19	152	1,6	17,5	61,5	178,5	213,7	7,9
80 (3")	79,4	58	203	88	127	152,4	4x19	191	1,6	22,2	76	199,1	350	14,3
100 (4")	101,6	80	229	104,1	157,2	190,5	8x19	229	1,6	22,2	92,5	215,5	450	25,9
150 (6")	151	111	267	125	216	241,3	8x22,2	279,5	1,6	23,8	129	221,5	465	43,8
200 (8")	198,75	144	292	135	270	298,4	8x22,2	343	1,6	27	158	251,5	715	77
250 (10")	254	187	330	165,5	324	362	12x25,4	406,4	1,6	28,7	191	305	774	114

(*) Dimensions in mm and weight in kg.

Series 730 (Class 300)

DN	ØJ	ØP	L	L1	ØQ	ØR	n x ØS	ØT	X	Y	h	H	M	WEIGHT
25 (1")	24,87	20	165	64,8	50,8	88,9	4x19	123,8	1,6	15,9	29	104,5	166	4,1
40 (1 1/2")	39,8	32	190	72	73	114,3	4x22,2	155,6	1,6	19	51	163	213,7	8,2
50 (2")	49,82	40	216	75,1	92	127	8x19	165,1	1,6	20,6	61,5	178,5	213,7	10,9
80 (3")	79,4	58	283	88	127	168,3	8x22,2	210,5	1,6	26,9	76	199,1	350	21,4
100 (4")	101,6	80	305	104,1	157,2	200	8x22,2	254	1,6	30,2	92,5	215,5	450	28,9
150 (6")	151	111	403	125	216	269,9	12x22,2	317,5	1,6	35	129	221,5	465	70
200 (8")	198,75	144	419	135	270	330,2	12x25,4	381	1,6	39,6	158	251,5	715	110,5

(*) Dimensions in mm and weight in kg.

Actuator connection

DN	ISO 5211	ØA	B	C	ØD	n x F	G	I	J
15 (1/2")	F05	35	22	8,1	50	4x M6	1,5	M10x1.5	7
20 (3/4")	F05	35	23	7,1	50	4x M6	3	M12x1.5	9
25 (1")	F05	35	23	7,7	50	4x M6	3	M12x1.5	9
40 (1 1/2")	F05	35	33,5	12,2	50	4xM6	3	M16x1.5	12
50 (2")	F07	55	41,5	18,2	70	4x M8	3	M18x1.5	13
80 (3")	F07	55	44	18	70	4x M8	3	M22x1.5	16
100 (4")	F10	70	44,5	18,7	102	4xM10	3	M25x1.5	18
150 (6")	F12	85	56,5	28,5	125	4xM12	3	M28x1.5	20
200 (8")	F12	85	56	27,6	125	4xM12	3	M35x2	25
250 (10")	F12	85	67	37	125	4xM12	3	M40x2	29

(*) Dimensions in mm



Comercial de Válvulas y Accesorios, S.A.
Polígono Industrial Polizur, Calle Bosc Tancat, 6 Nave 2 y 3
08290 Cerdanyola del valles (Barcelona) - Spain Tel. 34 93 586 36 00 Fax 34 93 586 36 04
e-mail: info@cva.es

URL: www.jlx-valve.com

Remarks: The dimensions of this catalogue are for reference only and it can change without previous notice

Ball Valves PN 20/50 (Class 150/300)

DN 15 - 250 (½" – 10") PN 20 (Class 150)
 DN 25 - 200 (1" – 8") PN 50 (Class 300)
 General Characteristics, Torque&KV, P&T Rating

GENERAL CHARACTERISTICS	Fig.715/730 Series EFR	End Entry Body	Floating Ball	Reduced Bore
DESIGN STANDARDS				
Valves design	API 6D	ASME B16.34	BS 5351	NF E 29-470
Body design	ASME VIII Div.1			
Shell thickness	ASME B16.34	BS 5351		
Flanges	ASME B16.5 Raised face			
Face to face dimensions	ASME B16.10 Short pattern	API 6D	EN 558-2 Series 3 & 4	
Actuator mounting flange	ISO 5211			
Wetted parts materials and bolting	NACE MR.01.75			
Shell finishing quality	MSS SP 55			
Marking	API 6D	BS 5351	NF E 29-470	CE - PED EN 19
TESTS AND CERTIFICATES				
Quality Assurance	ISO 9001	API Q1	CE - PED	
Fire Safe certification	BS 6755 Part 2	API 6FA	ISO 10497	API 607 4 TH Edition
Pressure testing	API 598	BS 6755 Part 1	ISO 5208	NF E 29-203 EN 12266
Other	ISO 14001	ATEX		

Torque Values in Nm

VALVE SIZE	AT DIFFERENTIAL PRESSURE		VALVE SIZE	AT DIFFERENTIAL PRESSURE	
	Class 150	Class 300		Class 150	Class 300
	20 bar	50 bar		20 bar	50 bar
DN 15 (½")	6		DN 80 (3")	40	60
DN 20 (¾")	9		DN 100 (4")	90	150
DN 25 (1")	10	16	DN 150 (6")	180	280
DN 40 (1½")	21	30	DN 200 (8")	250	420
DN 50 (2")	25	35	DN 250 (10")	600	

Kv Values in m³/h

DN 15 (½")	DN 20 (¾")	DN 25 (1")	DN 40 (1½")	DN 50 (2")	DN 80 (3")	DN 100 (4")	DN 150 (6")	DN 200 (8")	DN 250 (10")
7	10	26	107	140	300	600	1000	2000	4100

Pressure-Temperature

For A216 Gr. WCB only. For other materials consult ASME B16.34

