

# Ball Valves PN 16 HIT Construction (Cast Iron)

---



## Fig. 150

Manufacturing program:

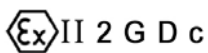

Quality & Environmental Management:



Comercial de Válvulas y Accesorios, S.L.  
Polígono Industrial Polizur, Calle Bosc Tancat, 6 Nave 2 y 3  
08290 Cerdanyola del valles ( Barcelona) – Spain Tel. 93 586 36 00 Fax 93 586 36 04  
e-mail: [info@cva.es](mailto:info@cva.es)  
URL: [www.cva.es](http://www.cva.es)

Nota: Las medidas del presente catalogo son orientativas y pueden variar sin previo aviso

# Ball Valves PN 16

## HIT Construction

### Parts and materials

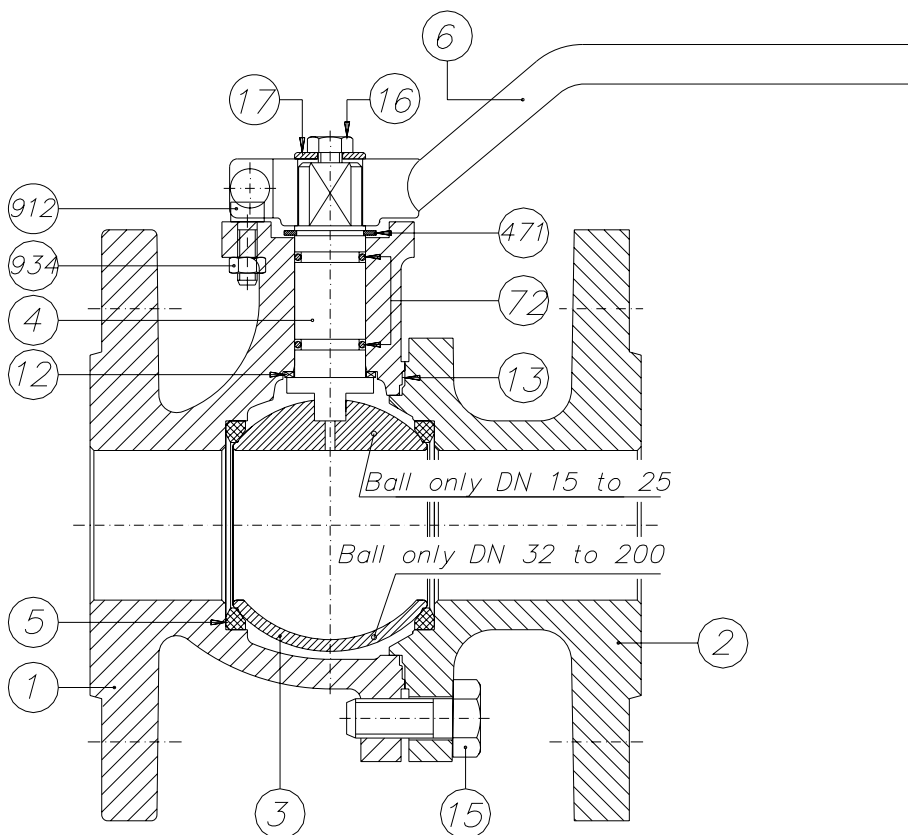

Item	Description	Material
1	Body	EN-GJL-250
2	Body connector	EN-GJL-250
3	Ball	DN 15 to 25: AISI 303 DN 32 to 200: AISI 304
4	Stem	AISI 304
5	Seat ring	PTFE
6	Wrench	Carbon steel
12	Stem thrust seal	PTFE
13	Body connector seal	PTFE
15	Bolt	DIN 933 5.6
16	Bolt	DIN 933 5.6
17	Washer	Zinc plated carbon steel
72	"O" Ring	FKM
471	Washer	DIN 471 Carbon St.
912	Bolt	DIN 912 8.8
934	Nut	DIN 934 8



Comercial de Válvulas y Accesorios, S.L.  
 Polígono Industrial Polizur, Calle Bosc Tancat, 6 Nave 2 y 3  
 08290 Cerdanyola del valles ( Barcelona) – Spain Tel. 93 586 36 00 Fax 93 586 36 04

e-mail: [info@cva.es](mailto:info@cva.es)

URL: [www.cva.es](http://www.cva.es)

Nota: Las medidas del presente catalogo son orientativas y pueden variar sin previo aviso

# Ball Valves PN 16 HIT Construction Dimensions

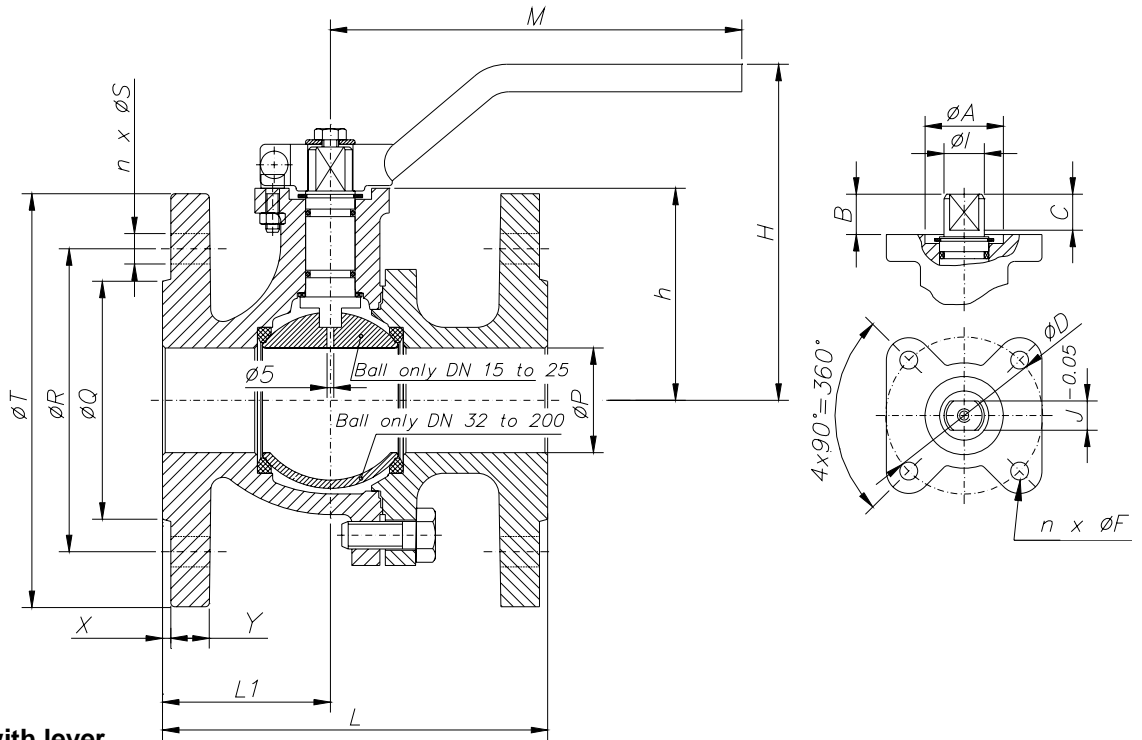

Valve with lever

DN	ØP	L	L1	ØQ	ØR	n x ØS	ØT	X	Y	h	M	H	WEIGHT
15 (½")	13	115	49	45	65	4x14	95	2	12	48,5	170	92	2,12
20 (¾")	17	120	55,5	58	75	4x14	105	2	14	53	170	95,5	2,72
25 (1")	24	125	51,5	68	85	4x14	115	2	14	59,5	170	102,2	3,62
32 (1¼")	31	130	53	78	100	4x18	140	2	14	72	170	114,7	5,32
40 (1½")	38	140	61	88	110	4x18	150	3	13	77	302,5	119	6,9
50 (2")	50	150	62	102	125	4x18	165	3	15	85	302,5	127	9
65 (2½")	65	170	81,5	122	145	4x18 (**)	185	3	15	98	224	141	11,68
80 (3")	80	180	79	138	160	8x18	200	3	17	108,5	335	151,5	14,68
100 (4")	100	190	94	158	180	8x18	220	3	17	134	350	176,5	20,23
125 (5")	125	325	120,5	188	210	8x18	250	3	19	165	350	208	33,73
150 (6")	150	350	155	212	240	8x22	285	3	19	190	500	254,5	49,77
200 (8")	200	400	190	268	295	12x22	340	3	21	229	500	293,5	81,77

(\* Dimensions in mm and weight in kg.

(\*\*) According to UNE-EN 1092-2 we can supply with 8 holes under client demand

## Free stem dimensions

DN	ISO 5211	ØA	B	C	ØD	n x ØF	ØI	J	WEIGHT
15 (½")	F04	19	7,5	5,5	42	4x5	10	7	2
20 (¾")	F04	19	6	5	42	4x5	10	7	2,6
25 (1")	F04	21	6,2	5	42	4x5	10	7	3,5
32 (1¼")	F04	21	6,7	5,5	42	4x5	10	7	5,2
40 (1½")	F04	30	15	16	42	4x5	16	12	6,5
50 (2")	F04	30	15	16	42	4x5	16	12	8,6
65 (2½")	F07	35	18	19	70	4x8	18	13	11
80 (3")	F07	35	18	19	70	4x8	18	13	14
100 (4")	F07	38	19	20	70	4x8	22	16	19,5
125 (5")	F07	38	19,5	20	70	4x8	22	16	33
150 (6")	F10	50	24,5	27	102	4x10	28	20	47,5
200 (8")	F10	50	24,5	27	102	4x10	28	20	79,5

(\* Dimensions in mm and weight in kg.



Comercial de Válvulas y Accesorios, S.L.  
Polígono Industrial Polizur, Calle Bosc Tanca, 6 Nave 2 y 3  
08290 Cerdanyola del valles ( Barcelona ) – Spain Tel. 93 586 36 00 Fax 93 586 36 04  
e-mail: [info@cva.es](mailto:info@cva.es)  
URL: [www.cva.es](http://www.cva.es)

Nota: Las medidas del presente catalogo son orientativas y pueden variar sin previo aviso

# Ball Valves PN 16 HIT Construction Dimensions

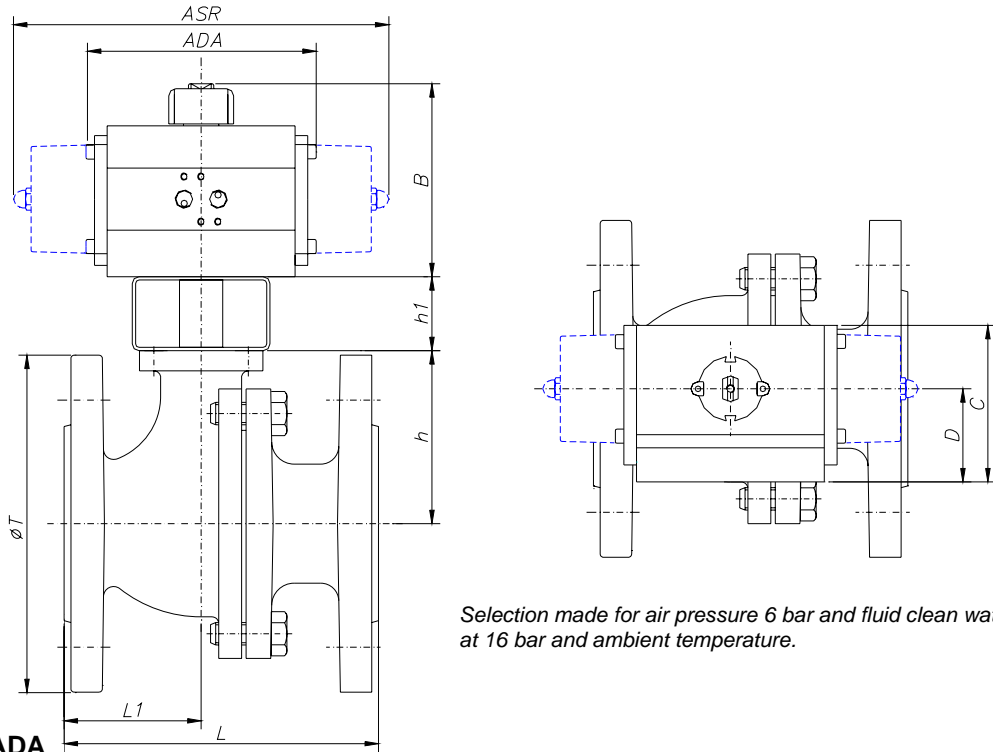

Selection made for air pressure 6 bar and fluid clean water at 16 bar and ambient temperature.

## Valve with ADA

DN	MODEL	ADA	B	C	D	L	L1	ØT	h	h1	WEIGHT
15 (½")	ADA-20	130	96	76	48	115	49	95	48,5	50	3,22
20 (¾")	ADA-20	130	96	76	48	120	55,5	105	53	50	3,82
25 (1")	ADA-20	130	96	76	48	125	51,5	115	59,5	50	4,72
32 (1¼")	ADA-20	130	96	76	48	130	53	140	72	50	6,42
40 (1½")	ADA-40	144	115	90	56	140	61	150	77	50	8,6
50 (2")	ADA-80	162	137	111	66	150	62	165	85	50	11,6
65 (2½")	ADA-80	162	137	111	66	170	81,5	185	98	50	14,28
80 (3")	ADA-130	182	146	121	71	180	79	200	108,5	50	18,1
100 (4")	ADA-200	211	165	135	78	190	94	220	134	50	25,33
125 (5")	ADA-500	275	199	172	96	325	120,5	250	165	60	44,23
150 (6")	ADA-500	275	199	172	96	350	155	285	190	60	60,27
200 (8")	ADA-850	336	217	192	106	400	190	340	229	70	97,77

(\*) Dimensions in mm and weight in kg.

## Valve with ASR

DN	MODEL	ASR	B	C	D	L	L1	ØT	h	h1	WEIGHT
15 (½")	ASR-20	215	96	76	48	115	49	95	48,5	50	3,62
20 (¾")	ASR-20	215	96	76	48	120	55,5	105	53	50	4,22
25 (1")	ASR-40	232	115	90	56	125	51,5	115	59,5	50	5,92
32 (1¼")	ASR-40	232	115	90	56	130	53	140	72	50	7,62
40 (1½")	ASR-80	270	137	111	66	140	61	150	77	50	10,9
50 (2")	ASR-130	297	146	121	71	150	62	165	85	50	14,5
65 (2½")	ASR-130	297	146	121	71	170	81,5	185	98	50	17,11
80 (3")	ASR-200	332	165	135	78	180	79	200	108,5	50	23,1
100 (4")	ASR-300	371	182	151	86	190	94	220	134	60	32,33
125 (5")	ASR-850	474	217	192	106	325	120,5	250	165	70	57,73
150 (6")	ASR-850	474	217	192	106	350	155	285	190	70	73,77
200 (8")	ASR-1750	614	280	242	131	400	190	340	229	80	179,6

(\*) Dimensions in mm and weight in kg.



Comercial de Válvulas y Accesorios, S.L.  
Polígono Industrial Polizur, Calle Bosc Tancat, 6 Nave 2 y 3  
08290 Cerdanyola del valles ( Barcelona) – Spain Tel. 93 586 36 00 Fax 93 586 36 04  
e-mail: [info@cva.es](mailto:info@cva.es)  
URL: [www.cva.es](http://www.cva.es)

Nota: Las medidas del presente catalogo son orientativas y pueden variar sin previo aviso

# Ball Valves PN 16

## HIT Construction

### General Characteristics, Torque, Kv, P&T Rating

GENERAL CHARACTERISTICS	Fig.150 Series <b>SFF</b>	<b>Split</b> Body	<b>Floating</b> Ball	<b>Full</b> Bore
<b>DESIGN STANDARDS</b>				
Valves design	DIN 3357			
Body design	DIN 3840			
Flanges	EN 1092-2 (DIN 2501)			
Face to face dimensions	EN 558-1 SERIE 27 (DIN 3202 F18)			
Actuator mounting flange	DIN 3337	ISO 5211		
Marking	EN 19	CE ≥ DN50		
<b>TESTS AND CERTIFICATES</b>				
Quality Assurance	ISO 9001			
Pressure testing	EN 12266-1			

#### Torque Values in Nm

VALVE SIZE	AT DIFFERENTIAL PRESSURE		VALVE SIZE	AT DIFFERENTIAL PRESSURE	
	16 bar			16 bar	
15 (½")	6		65 (2½")	41	
20 (¾")	6		80 (3")	71	
25 (1")	11		100 (4")	119	
32 (1¼")	12		125 (5")	190	
40 (1½")	26		150 (6")	220	
50 (2")	41		200 (8")	450	

Given torques with clean water at ambient temperature.

#### Kv Values in m<sup>3</sup>/h

VALVE SIZE	Kv	VALVE SIZE	Kv
15 (½")	37,4	65 (2½")	660
20 (¾")	74,8	80 (3")	1200
25 (1")	105	100 (4")	1980
32 (1¼")	176	125 (5")	3600
40 (1½")	223	150 (6")	5040
50 (2")	416	200 (8")	10890

#### Pressure-Temperature

P (bar)

\* Depending on FKM resistance to the fluid.

