

Forged Gate Valves
Fig. C800 Class 800
Size ½" – 2" (DN 15 – 50)



FIG. C800
GATE VALVE

API 602, MSS SP 118 & ASME B16.34

Connections according to:

ANSI B 1.20.1 (NPT)

ANSI B 16.11 (SW)

CE



Comercial de Válvulas y Accesorios, S.L.
Polígono Industrial Polizur, Calle Bosc Tancat, 6 Nave 2 y 3
08290 Cerdanyola del valles (Barcelona) – Spain Tel. 93 586 36 00 Fax 93 586 36 04
e-mail: info@cva.es
URL: www.cva.es

Nota: Las medidas del presente catalogo son orientativas y pueden variar sin previo aviso

Forged Gate Valves

Fig. C800 Class 800

Parts and Materials

Parts and materials

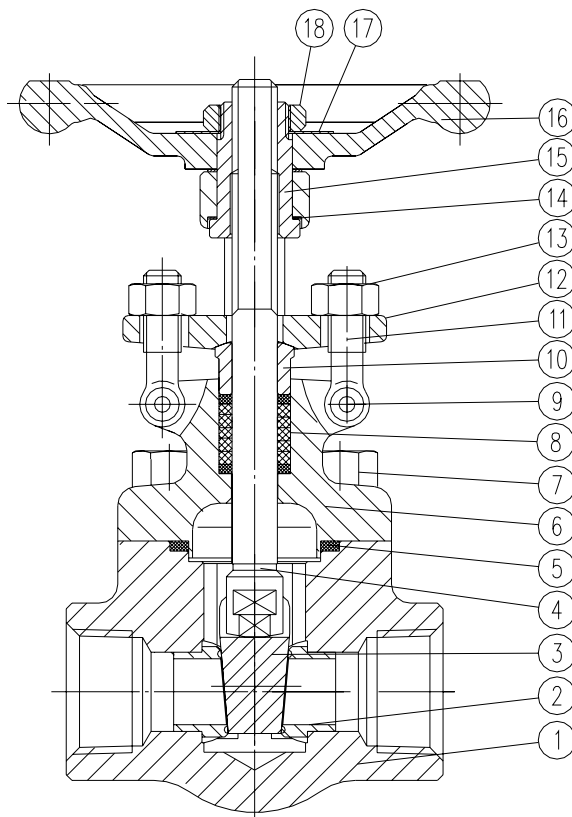

Item	Description	Material	
		Carbon Steel	Stainless Steel
1	Body	A 105	A 182 F316L
2	Seat	A 182 F6A + STL	A 182 F316L + STL
3	Gate	A 182 F6A + STL	A 182 F316L
4	Stem	AISI 410	A 182 F316L
5	Gasket	AISI 304 + Graphite	AISI 316 + Graphite
6	Bonnet	A 105	A 182 F316L
7	Bolt	A 193 B7	A 193 B8M
8	Packing	Flexible Graphite + Carbon Fibre	
9	Pin	AISI 420	AISI 304
10	Packing Gland	AISI 420	AISI 316L
11	Eye Bolt	A 193 B8	A 193 B8M
12	Gland Flange	A 105	A 182 F316L
13	Hex Nut	A 194 8	A 194 8M
14	Washer	AISI 410	
15	Yoke Nut	AISI 410	
16	Handwheel	A 197	
17	Nameplate	Aluminium	
18	Hex Nut	1035 Zinc Plated	



Comercial de Válvulas y Accesorios, S.L.
 Polígono Industrial Polizur, Calle Bosc Tancat, 6 Nave 2 y 3
 08290 Cerdanyola del valles (Barcelona) – Spain Tel. 93 586 36 00 Fax 93 586 36 04
 e-mail: info@cva.es
 URL: www.cva.es

Nota: Las medidas del presente catalogo son orientativas y pueden variar sin previo aviso

Forged Gate Valves

Fig. C800 Class 800

Dimensions

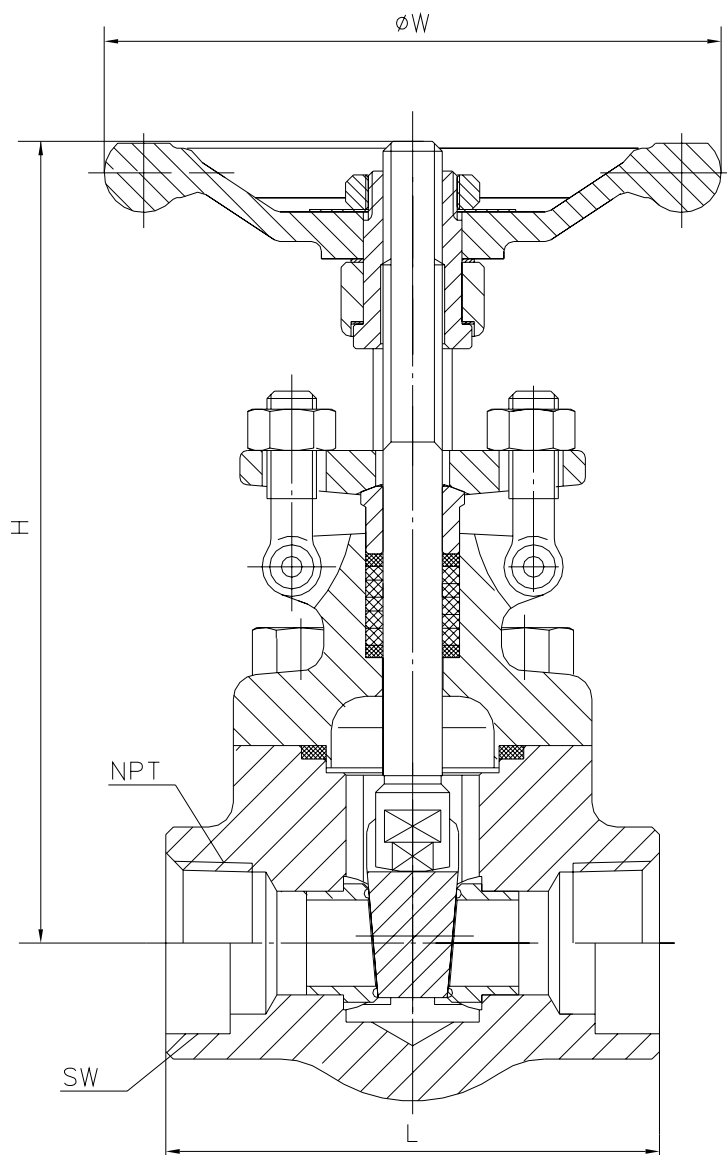

Dimensions

SIZE	L	NPT	ϕW	H	Weight
½" (DN 15)	79	½"	100	151	2,2
¾" (DN 20)	92	¾"	100	158	2,4
1" (DN 25)	111	1"	125	185	4,2
1¼" (DN 32)	120	1¼"	160	239	6
1½" (DN 40)	120	1½"	160	243	7
2" (DN 50)	140	2"	180	279	11

(*) Dimensions in mm and weight in kg.



Comercial de Válvulas y Accesorios, S.L.
 Polígono Industrial Polizur, Calle Bosc Tancat, 6 Nave 2 y 3
 08290 Cerdanyola del valles (Barcelona) – Spain Tel. 93 586 36 00 Fax 93 586 36 04
 e-mail: info@cva.es
 URL: www.cva.es

Nota: Las medidas del presente catalogo son orientativas y pueden variar sin previo aviso

Forged Gate Valves

Fig. C800 Class 800

General Characteristics, Torque, KV, P&T Rating

GENERAL CHARACTERISTICS	Forged Gate Valve		
DESIGN STANDARDS			
Valves design	API 602	ASME B 16.34	
Connections	ANSI B 1.20.1	ANSI B 16.11	
Face to face dimensions	Manufacturer's standard		
TESTS AND CERTIFICATES	API 598		
Quality Assurance	ISO 9001		
Pressure testing	EN 12266-1		
Marking	EN 19		

Kv Values in m³/h

VALVE SIZE	Kv	VALVE SIZE	Kv
½" (DN 15)	15	1¼" (DN 32)	80
¾" (DN 20)	15	1½" (DN 40)	80
1" (DN 25)	29	2" (DN 50)	135

Pressure-Temperature

P Bar

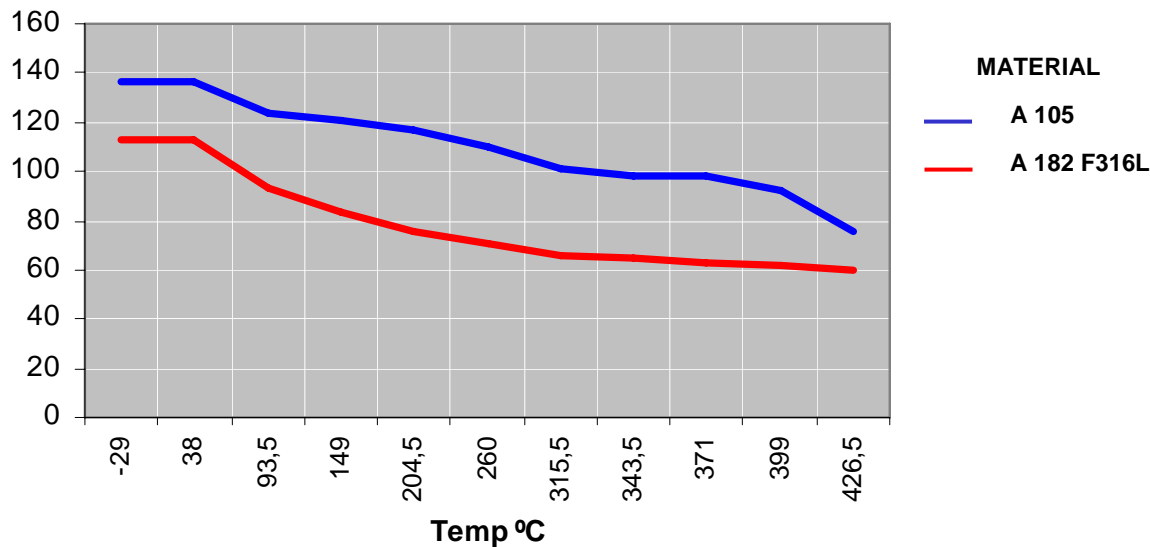

Comercial de Válvulas y Accesorios, S.L.
 Polígono Industrial Polizur, Calle Bosc Tancat, 6 Nave 2 y 3
 08290 Cerdanyola del valles (Barcelona) – Spain Tel. 93 586 36 00 Fax 93 586 36 04
 e-mail: info@cva.es
 URL: www.cva.es

Nota: Las medidas del presente catalogo son orientativas y pueden variar sin previo aviso