

Forged Globe Valves
Fig. G800 Class 800
Size ½” – 2” (DN 15 – 50)



FIG. G800
GLOBE VALVE

BS 5352, ASME B16.34
Connections according to:
ANSI B 1.20.1 (NPT)
ANSI B 16.11 (SW)
CE



Comercial de Válvulas y Accesorios, S.L.
Polígono Industrial Polizur, Calle Bosc Tancat, 6 Nave 2 y 3
08290 Cerdanyola del valles (Barcelona) – Spain Tel. 93 586 36 00 Fax 93 586 36 04
e-mail: info@cva.es
URL: www.cva.es

Nota: Las medidas del presente catalogo son orientativas y pueden variar sin previo aviso

Forged Globe Valves

Fig. G800 Class 800

Parts and Materials

Parts and materials

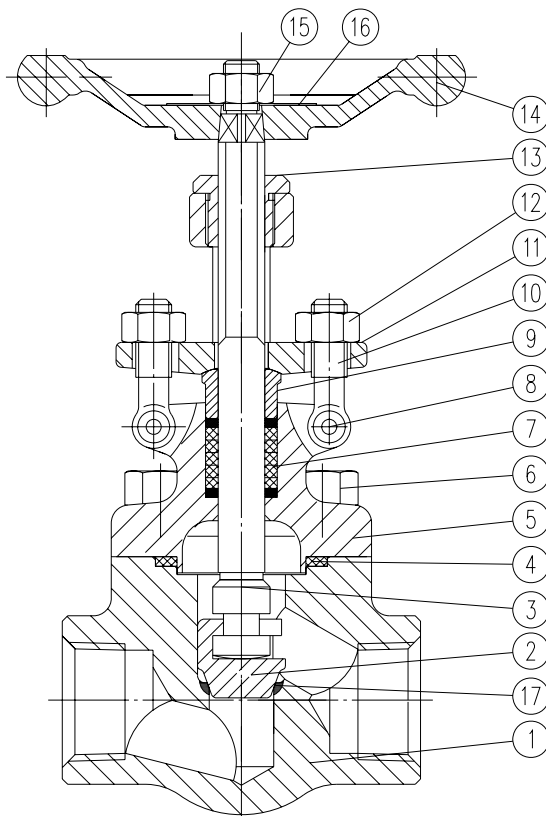

Item	Description	Material	
		Carbon Steel	Stainless Steel
1	Body	A 105	A 182 F316L
2	Disc	AISI 420 + STL	A 182 F316L
3	Stem	AISI 410	A 182 F316L
4	Gasket	AISI 304 + Graphite	AISI 316 + Graphite
5	Bonnet	A 105	A 182 F316L
6	Bolt	A 193 B7	A 193 B8M
7	Packing	Flexible Graphite + Carbon Fibre	
8	Pin	AISI 420	AISI 304
9	Packing Gland	AISI 420	AISI 316L
10	Eye Bolt	A 193 B8	A 193 B8M
11	Gland Flange	A 105	A 182 F316L
12	Hex Nut	A 194 8	A 194 8M
13	Yoke Nut	AISI 410	
14	Handwheel	A 197	
15	Hex Nut	1035 Zinc Plated	
16	Nameplate	Aluminium	
17	Seat	A 105 + STL	A 182 F316L + STL



Comercial de Válvulas y Accesorios, S.L.
 Polígono Industrial Polizur, Calle Bosc Tancat, 6 Nave 2 y 3
 08290 Cerdanyola del valles (Barcelona) – Spain Tel. 93 586 36 00 Fax 93 586 36 04

e-mail: info@cva.es

URL: www.cva.es

Nota: Las medidas del presente catalogo son orientativas y pueden variar sin previo aviso

Forged Globe Valves

Fig. G800 Class 800

Dimensions

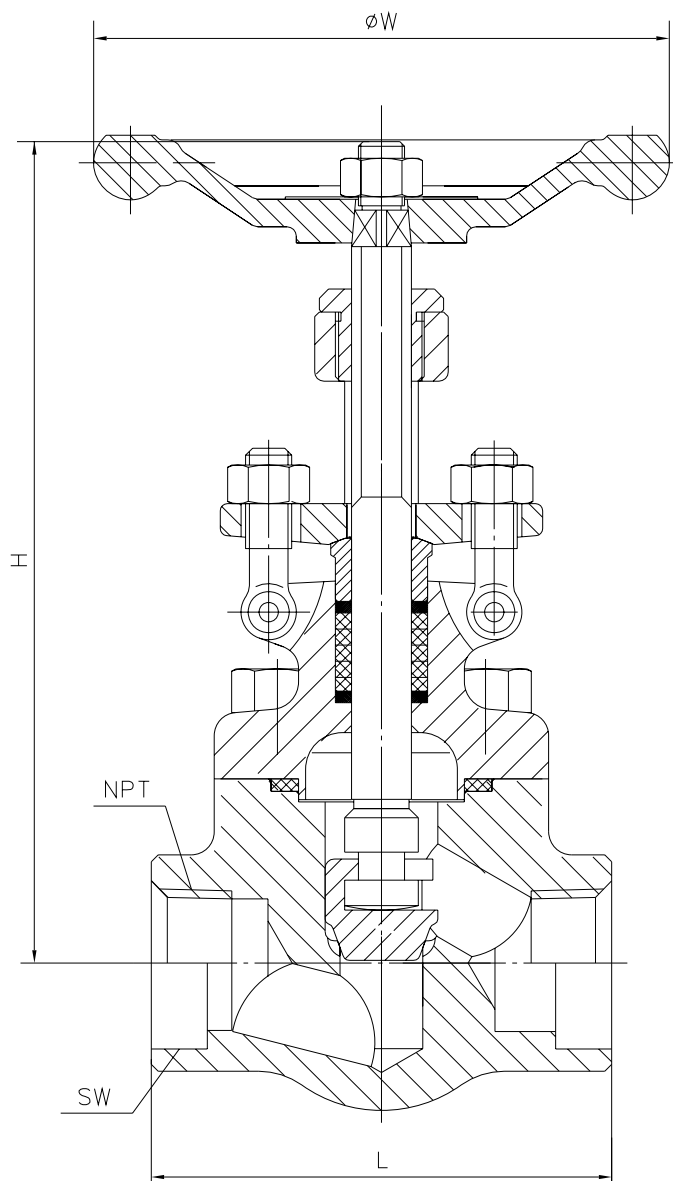

Dimensions

SIZE	L	NPT	$\varnothing W$	H	Weight
1/2" (DN 15)	79	1/2"	100	158	2,2
3/4" (DN 20)	92	3/4"	100	163	2,4
1" (DN 25)	111	1"	125	193	4,2
1 1/4" (DN 32)	152	1 1/4"	160	250	6
1 1/2" (DN 40)	152	1 1/2"	160	250	8
2" (DN 50)	172	2"	180	291	12,8

(*) Dimensions in mm and weight in kg.



Comercial de Válvulas y Accesorios, S.L.
 Polígono Industrial Polizur, Calle Bosc Tancat, 6 Nave 2 y 3
 08290 Cerdanyola del valles (Barcelona) – Spain Tel. 93 586 36 00 Fax 93 586 36 04

e-mail: info@cva.es

URL: www.cva.es

Nota: Las medidas del presente catalogo son orientativas y pueden variar sin previo aviso

Forged Globe Valves

Fig. G800 Class 800

General Characteristics, Torque, Kv, P&T Rating

GENERAL CHARACTERISTICS	Forged Globe Valve		
DESIGN STANDARDS			
Valves design	BS 5352	ASME B16.34	
Connections	ANSI B 1.20.1	ANSI B 16.11	
Face to face dimensions	Manufacturer's standard		
TESTS AND CERTIFICATES	API 598		
Quality Assurance	ISO 9001		
Pressure testing	EN 12266-1		
Marking	EN 19		

Kv Values in m³/h

VALVE SIZE	Kv	VALVE SIZE	Kv
½" (DN 15)	22,3	1¼" (DN 32)	642,7
¾" (DN 20)	42,8	1½" (DN 40)	1114
1" (DN 25)	80,5	2" (DN 50)	1970

Pressure-Temperature

P Bar

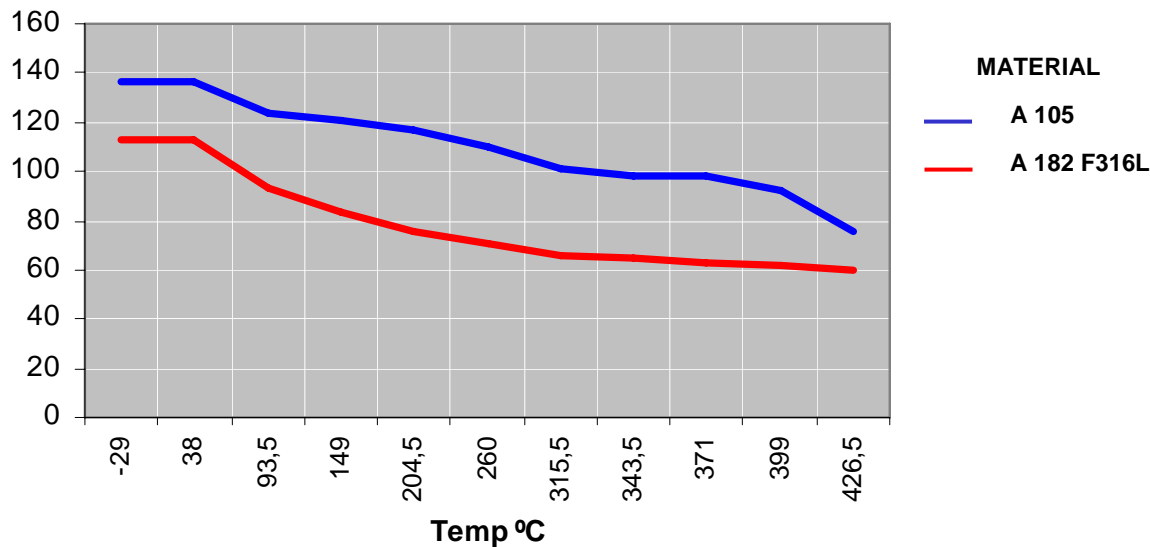

Comercial de Válvulas y Accesorios, S.L.
 Polígono Industrial Polizur, Calle Bosc Tancat, 6 Nave 2 y 3
 08290 Cerdanyola del valles (Barcelona) – Spain Tel. 93 586 36 00 Fax 93 586 36 04

e-mail: info@cva.es

URL: www.cva.es

Nota: Las medidas del presente catalogo son orientativas y pueden variar sin previo aviso