

**BS 1868 & API 6D, ISO 14313,  
ASME B16.34**



Item	Description	Material of construction**			
		Carbon Steel	Carbon Steel (Low Temp.)	Alloy Steel	Stainless Steel
1	Body	A 216 Gr.WCB	A 352 Gr.LCB	A 217 Gr.C5	A 351 Gr.CF8M
4	Disc	A105 + ER 410	A 182 Gr.F304	A 182 Gr.F6a	A 182 Gr.F316
5	Seat Ring	A105 + Stellite	A 182 Gr.F304	A 182 Gr.F6a + Stellite	----
13	Cover	A 216 Gr.WCB / A 515	A 352 Gr.LCB / A 182	A 217 Gr.C5	A 351 Gr.CF8M
20	Cover Bolt & Nut	A 193 Gr.B7 / A 194 Gr.2H	A 193 Gr.B7 / A 194 Gr.2H	A 193 Gr.B7 / A 194 Gr.2H	A 193 Gr.B7 / A 194
27	Bracket Stud &	A 193 Gr.B8 / A 194 Gr.8	A 193 Gr.B8 / A 194 Gr.8	A 193 Gr.B8 / A 194 Gr.8	A 193 Gr.B8M / A 194
28	Gasket	SPW S.S. 304 / Graphite	SPW S.S. 304 / Graphite	SPW S.S. 304 / Graphite	SPW S.S. 316 / Graphite
38	Washer	AISI 410	AISI 304	AISI 410	AISI 316
40	Disc Nut	AISI 304	AISI 304	AISI 304	AISI 316
48	Hinge Pin *	A182 Gr.F6a	A182 Gr.F304	A182 Gr.F6a	A 182 Gr.F316
50	Split Pin	AISI 304	AISI 304	AISI 304	AISI 316
57	Hinge	A 216 Gr.WCB / A 515	A 352 Gr.LCB	A 217 Gr.C5	A 351 Gr.CF8M
58	Hinge Bracket	A 216 Gr.WCB / A 515	A 352 Gr.LCB	A 217 Gr.C5	A 351 Gr.CF8M
59	Lifting Hook	A105	A105	A105	A105

(3) Zinc coating

\* It's also manufactured with Hinge Pin Passing through Body with Plug

\*\* Standard constructions with Trim 8, 2 and 10, other options are available

API 600 Trim No.	Nominal Trim	Stem / Backseat (1)	Seating Surface Body / Wedge
1	F6	13Cr	13Cr
2	304	18Cr-8Ni	18Cr-8Ni
3	F310	25Cr-20Ni	25Cr-20Ni
4	Hard F6	13Cr	Hard 13Cr
5	Hardfaced	13Cr	Co-Cr A (2)
5A	Hardfaced	13Cr	Ni-Cr
6	F6 and Cu-Ni	13Cr	13Cr and Cu-Ni
7	F6 and Hard F6	13Cr	13Cr and Hard 13Cr
8	F6 and Hardfaced	13Cr	13Cr and Co-Cr A (2)
8A	F6 and Hardfaced	13Cr	13Cr and Ni-Cr
9	Monel	Ni-Cu Alloy	Ni-Cu Alloy
10	316	18Cr-8Ni-Mo	18Cr-8Ni-Mo
11	Monel and Hardfaced	Ni-Cu Alloy	Ni-Cu Alloy and Trim 5 or 5A
12	316 and Hardfaced	18Cr-8Ni-Mo	18Cr-8Ni-Mo and Trim 5 or 5A
13	Alloy 20	19Cr-29Ni	19Cr-29Ni
14	Alloy 20 and	19Cr-29Ni	19Cr-29Ni and Trim 5 or 5A
15	Hardfaced	18Cr-8Ni	Co-Cr A (2)
16	Hardfaced	18Cr-8Ni-Mo	Co-Cr A (2)
17	Hardfaced	18Cr-10Ni-Cb	Co-Cr A (2)
18	Hardfaced	19Cr-29Ni	Co-Cr A (2)

(1) and small internal parts that normally contact the service fluid

(2) Trademark material Stellite 6

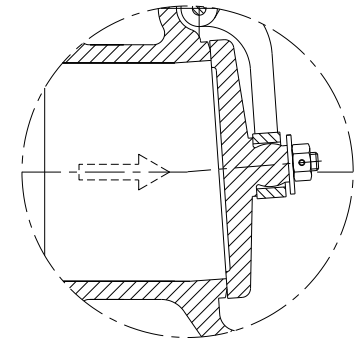
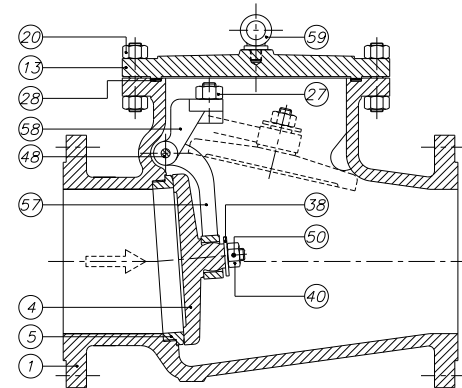

**Stainless Steel Construction**

DN	A (RF/BW)	B	WEIGHT
50 (2")	292	197	26
65 (2½")	330	207	45
80 (3")	356	231	68
100 (4")	432	281	90
125 (5")	508	319	140
150 (6")	559	362	200
200 (8")	660	437	360
250 (10")	787	490	673
300 (12")	838	528	875
350 (14")	889	572	944
400 (16")	991	660	1220

(\*) Dimensions in mm and weight in kg  
 For other sizes consult to the technical department.

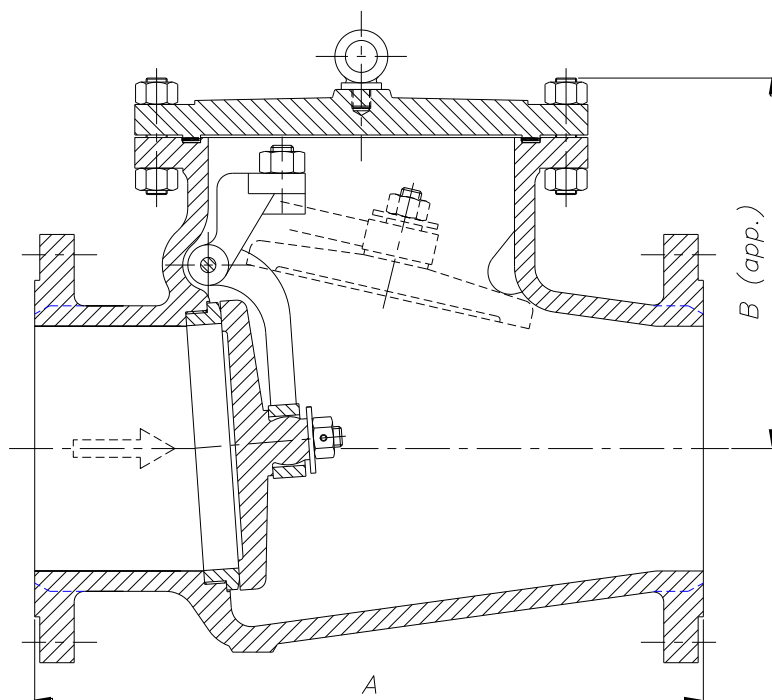

DESIGN STANDARDS				
Valves design	BS 1868	API 6D	ASME B16.34	
End to End Dimensions	ASME B16.10	ISO 5752		
Flanged Dimensions	ASME B16.5	ISO 7005- Pat. 1	BS 3293	MSS SP-44
Buttweld Dimensions	ASME B16.25			
Visual Inspection	MSS SP- 55			
Marking	MSS SP-25	ISO 5209		
TESTS AND CERTIFICATES				
Pressure testing	API 598	ISO 5208	EN 12266-1	MSS SP-61
Others			CE	

Cv VALUES IN US Gallons/min			
DN	Cv	DN	Cv
50 (2")	125	200 (8")	2200
65 (2½")	190	250 (10")	3300
80 (3")	280	300 (12")	4800
100 (4")	490	350 (14")	5850
125 (5")	800	400 (16")	8100
150 (6")	1150		

PRESSURE - TEMPERATURE (Standard Class According to ASME B16.34)				
Temp	MATERIAL			
	A216 WCB	A352 LCB	A217 C5	A351 CF8M (**)
°C	Bar	Bar	Bar	Bar
-29 to 38	102,0	95,8	103,4	99,2
95	93,0	90,6	102,7	85,4
150	90,6	87,8	98,5	77,2
205	87,5	85,1	87,1	70,6
260	82,7	80,3	91,6	65,8
315	75,4	73,4	83,4	62,0
345	74,1	72,0	81,0	61,3
375	73,4		78,2	59,9
400	69,6		72,7	58,9
425	56,8		69,9	58,2
450	36,9		66,5	57,5
485	23,8		51,0	57,2
510	14,1		37,9	53,4
540	7,2		27,6	48,2
565			20,0 *	47,2 *
595			13,8 *	42,0 *
620			8,6 *	32,7 *
650			4,8 *	25,5 *
675				20,3 *
705				16,2 *
735				13,1 *
760				10,3 *
790				7,9 *
815				5,9 *

\* FOR WELD END VALVES ONLY. FLANGE END RATINGS TERMINATE AT 540°C

\*\* A351 CF8M at temperatures over 538°C (1000°F) to be used only if Carbon contents is 0,04% or higher.