

BS 1873 & ASME B16.34



Item	Description	Material of construction*			
		Carbon Steel	Carbon Steel (Low Temp.)	Alloy Steel	Stainless Steel
1	Body	A 216 Gr.WCB	A 352 Gr.LCB	A 217 Gr.C5	A 351 Gr.CF8M
2	Bonnet	A 216 Gr.WCB	A 352 Gr.LCB	A 217 Gr.C5	A 351 Gr.CF8M
4	Disc	A 105 + ER 410	A 182 Gr.F304	A 217 Gr.C5 + ER 410	A 351 Gr.CF8M
5	Seat Ring	A 105 + Stellite	A 182 Gr.F304	A 182 Gr.F6a + Stellite	----
6	Backseat	A 182 Gr.F6a	A 182 Gr.F304	A 182 Gr.F6a	----
7	Stem	A 182 Gr.F6a	A 182 Gr.F304	A 182 Gr.F6a	A 182 Gr.F316
8	Gland	A 105	A 105	A 182 Gr. F6a	A 182 Gr.F316
9	Gland Flange	A 105	A 105	A 105	A 182 Gr.F304
11	Stem Nut	B 148 / A 439 Gr.D2	B 148 / A 439 Gr.D2	B 148 / A 439 Gr.D2	B 148 / A 439 Gr.D2
12	Disc Nut	A 182 Gr.F6a	A 182 Gr.F304	A 182 Gr.F6a	A 182 Gr.F316
18	Handw heel	Carbon Steel	Carbon Steel	Carbon Steel	Carbon Steel
19	Handw heel Nut	Steel	Steel	Steel	Steel
20	Bonnet Bolt & Nut	A 193 Gr.B7 / A 194 Gr.2H	A 193 Gr.B7 / A 194 Gr.2H	A 193 Gr.B7 / A 194 Gr.2H	A 193 Gr.B7 / A 194 Gr.2H (3)
21	Eye Bolt & Nut	A 193 Gr.B7 / A 194 Gr.2H	A 193 Gr.B7 / A 194 Gr.2H	A 193 Gr.B7 / A 194 Gr.2H	A 193 Gr.B7 / A 194 Gr.2H
28	Gasket	SPW S.S. 304 / Graphite	SPW S.S. 304 / Graphite	SPW S.S. 304 / Graphite	SPW S.S. 316 / Graphite
29	Stem Packing	Graphite	Graphite	Graphite	Graphite
37	Thrust Washer	A 182 Gr.F6a	A 182 Gr.F304	A 182 Gr.F6a	A 182 Gr.F316
38	Washer	Steel	Steel	Steel	Steel
42	Grub Screw	A 193 Gr.B7	A 193 Gr.B7	A 193 Gr.B7	A 193 Gr.B7
45	Lock Nut	Steel	Steel	A 182 Gr.F6a	A 182 Gr.F316

(3) Zinc coating

* Standard constructions with Trim 8, 2 and 10, other options are available

API 600 Trim No.	Nominal Trim	Stem Backseat (1)	Seating Surface Body/Wedge
1	F6	13Cr	13Cr
2	304	18Cr-8Ni	18Cr-8Ni
3	F310	25Cr-20Ni	25Cr-20Ni
4	Hard F6	13Cr	Hard 13Cr
5	Hardfaced	13Cr	Co-Cr A (2)
5A	Hardfaced	13Cr	Ni-Cr
6	F6 and Cu-Ni	13Cr	13Cr and Cu-Ni
7	F6 and Hard F6	13Cr	13Cr and Hard 13Cr
8	F6 and Hardfaced	13Cr	13Cr and Co-Cr A (2)
8A	F6 and Hardfaced	13Cr	13Cr and Ni-Cr
9	Monel	Ni-Cu Alloy	Ni-Cu Alloy
10	316	18Cr-8Ni-Mo	18Cr-8Ni-Mo
11	Monel and Hardfaced	Ni-Cu Alloy	Ni-Cu Alloy and Trim 5 or 5A
12	316 and Hardfaced	18Cr-8Ni-Mo	18Cr-8Ni-Mo and Trim 5 or 5A
13	Alloy 20	19Cr-29Ni	19Cr-29Ni
14	Alloy 20 and Hardfaced	19Cr-29Ni	19Cr-29Ni and Trim 5 or 5A
15	Hardfaced	18Cr-8Ni	Co-Cr A (2)
16	Hardfaced	18Cr-8Ni-Mo	Co-Cr A (2)
17	Hardfaced	18Cr-10Ni-Cb	Co-Cr A (2)
18	Hardfaced	19Cr-29Ni	Co-Cr A (2)

(1) and small internal parts that normally contact the service fluid

(2) Trademark material Stellite 6

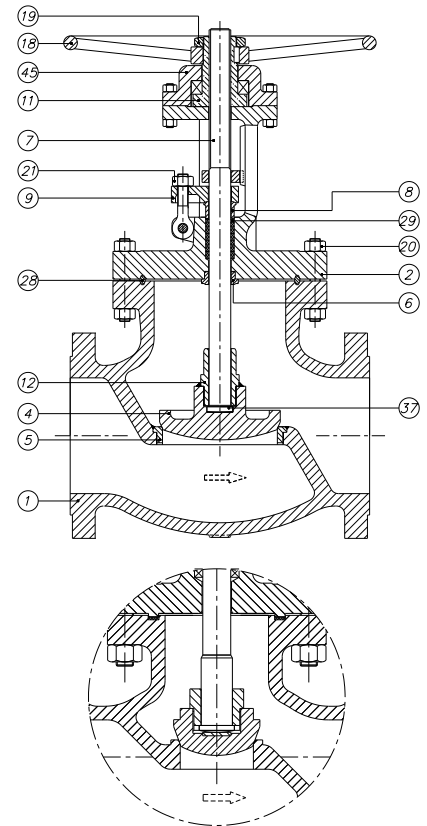

Stainless Steel Construction

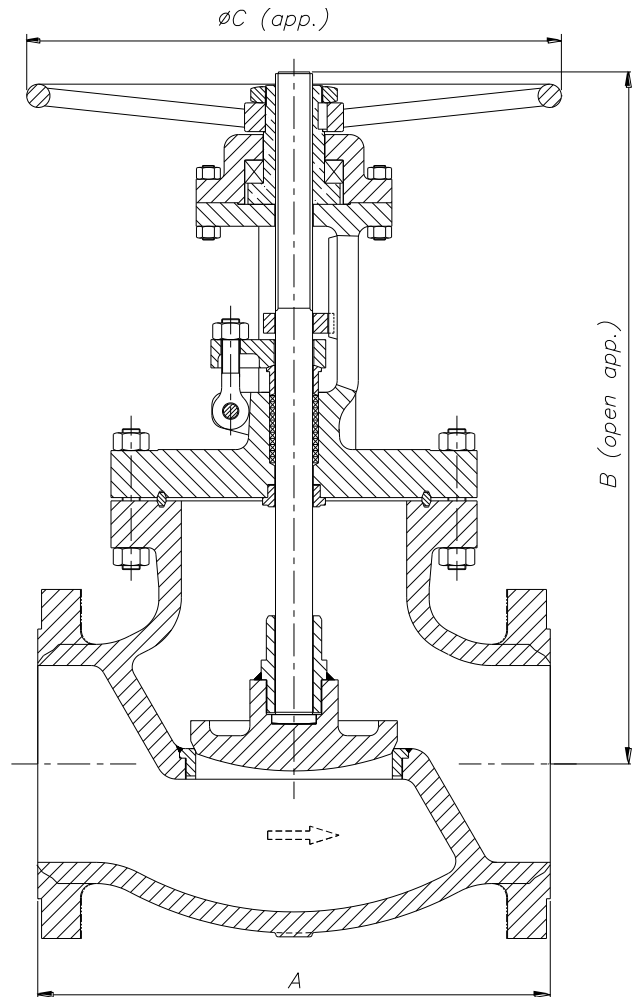

DN	A (RF/BW)	B	$\varnothing C$	WEIGHT
50 (2")	368	592	350	112
65 (2½")	419	605	450	175
80 (3")	470	692	450	228
100 (4")	546	907	460	336
125 (5")	673	965	560	585
150 (6")	705	1015	610	822
200 (8")	832	1145	610	960

(*) Dimensions in mm and weight in kg
For other sizes consult to the technical department.

DESIGN STANDARDS				
Valves design	BS 1873	ASME B16.34		
End to End Dimensions	ASME B16.10	ISO 5752		
Flanged Dimensions	ASME B16.5	ISO 7005- Pat. 1	BS 3293	MSS SP-44
Buttweld Dimensions	ASME B16.25			
Visual Inspection	MSS SP- 55			
Marking	MSS SP-25	ISO 5209		
TESTS AND CERTIFICATES				
Pressure testing	API 598	ISO 5208	EN 12266-1	MSS SP-61
Others			CE	

Cv VALUES IN US Gallons/min			
DN	Cv	DN	Cv
50 (2")	40	125 (5")	250
65 (2½")	65	150 (6")	360
80 (3")	85	200 (8")	600
100 (4")	120		

PRESSURE - TEMPERATURE (Standard Class According to ASME B16.34)				
Temp	MATERIAL			
	A216 WCB	A352 LCB	A217 C5	A351 CF8M (**)
°C	Bar	Bar	Bar	Bar
-29 to 38	255,3	239,1	258,4	248,0
95	232,5	226,0	256,7	213,2
150	226,0	219,8	246,7	192,6
205	218,4	212,6	243,2	177,1
260	206,4	200,5	229,1	164,7
315	188,4	183,6	208,4	155,4
345	185,0	180,2	202,6	153,0
375	183,6		195,7	149,5
400	173,6		181,9	147,1
425	141,9		175,0	145,4
450	92,3		166,4	144,0
485	59,3		127,5	143,0
510	35,5		94,4	133,0
540	17,9		68,6	120,6
565			49,6 *	118,5 *
595			34,1 *	105,1 *
620			21,4 *	81,6 *
650			11,7 *	63,7 *
675				50,6 *
705				40,3 *
735				33,1 *
760				26,2 *
790				20,0 *
815				14,1 *

* FOR WELD END VALVES ONLY. FLANGED END RATINGS TERMINATE AT 540°C

** A351 CF8M at temperatures over 538°C (1000°F) to be used only if Carbon contents is 0,04% or higher.